

数控刀柄系列 CNC TOOL SYSTEMS

CD1111-01 HSK莫氏变径套 HSK MORSE TAPER SLEEVE(TYPE A)

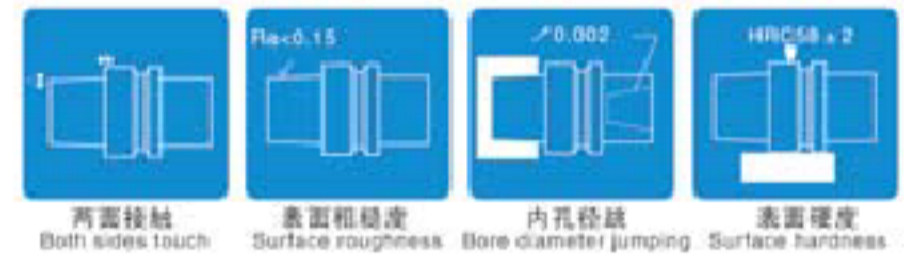
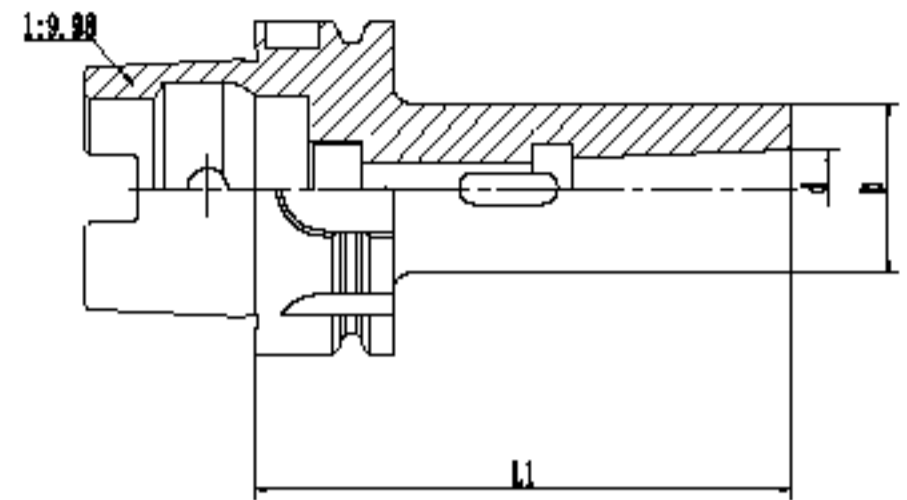

型号 Model No.	柄部 Shank	d	D	L1
HSK63A-MTA1-100	HSK63A	12.065	25	100
HSK63A-MTA2-120	HSK63A	17.78	32	120
HSK63A-MTA3-140	HSK63A	23.825	40	140
HSK63A-MTA4-160	HSK63A	31.267	48	160
HSK100A-MTA1-110	HSK100A	12.065	25	110
HSK100A-MTA2-120	HSK100A	17.78	32	120
HSK100A-MTA3-150	HSK100A	23.825	40	150
HSK100A-MTA4-170	HSK100A	31.267	48	170
HSK100A-MTA5-200	HSK100A	44.399	63	200

CD1111-02 HSK后拉式 变径套 HSK MORSE TAPER SLEEVE(TYPE B)

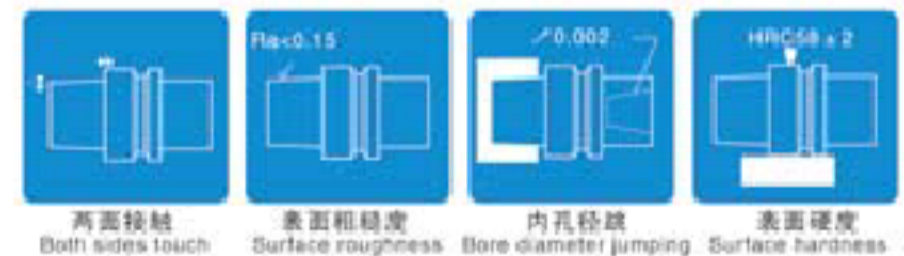
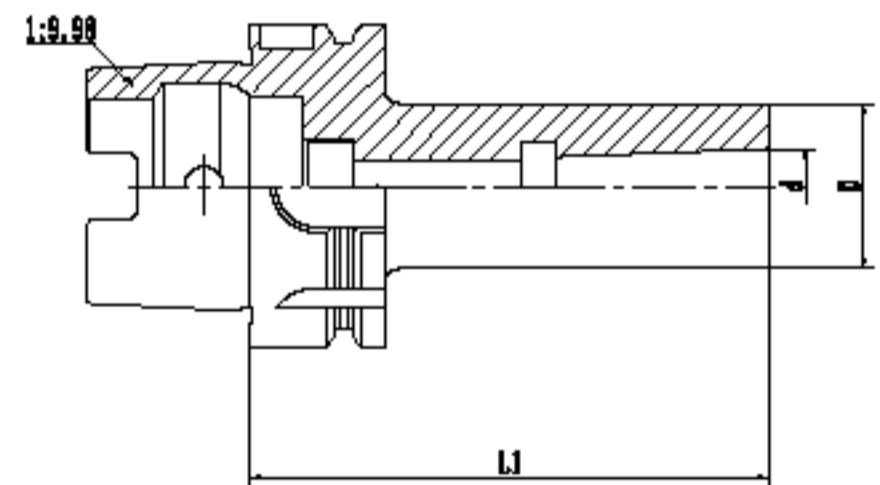

型号 Model No.	柄部 Shank	d	D	L1
HSK63A-MTB1-100	HSK63A	12.065	25	100
HSK63A-MTB2-120	HSK63A	17.78	32	120
HSK63A-MTB3-140	HSK63A	23.825	40	140
HSK63A-MTB4-160	HSK63A	31.267	48	160
HSK100A-MTB1-110	HSK100A	12.065	25	110
HSK100A-MTB2-120	HSK100A	17.78	32	120
HSK100A-MTB3-150	HSK100A	23.825	40	150
HSK100A-MTB4-170	HSK100A	31.267	48	170
HSK100A-MTB5-200	HSK100A	44.399	63	200